

## Special Engineered Products

Royal can provide a complete range of options in the designing and building of all types of custom-made and specially-built chucks.



**Large Diameter Ultra-High Speed Wheel Chuck**  
Special 24" Diameter 3-Jaw, Wedge Type, Ultra-High Speed Wheel Chuck with 5/8" jaw movement (1-1/4" on diameter) provides accurate repetitive chucking on 17, 19, 22, and 24" diameter wheels. The unique counter-balanced system's consistent gripping force throughout the speed range (up to 1,800 rpm) assures the production of distortion-free wheels.

### Unique Double Collet Chuck

Double Collet 12" Diameter Chuck was custom-designed and *built to grip the flanged ends of 1/2" through 2" investment cast valve bodies* is easily adapted to lathes requiring a single draw bar or draw tube operation. Work parts having the same or different locating diameters were held several inches apart...draw-back feature provided positive end location.

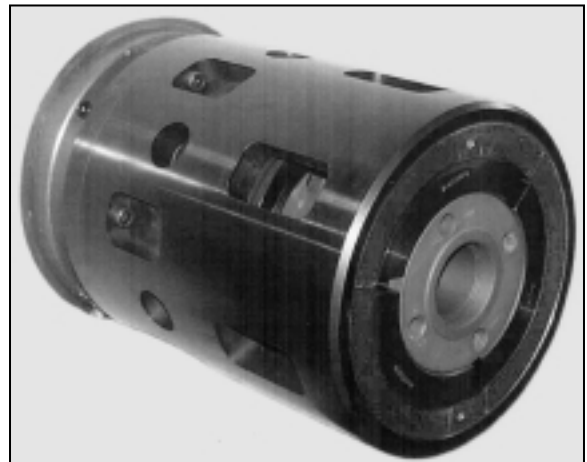

### Special 6-Jaw Power Chuck

Special 15" Diameter 6-Jaw Power Chuck with 4.81" diameter through-hole was *specially designed for gripping thin wall tubing*. Chuck was configured with American Standard Acme Serrated Master Jaws, 3/8" jaw movement, (3/4" on diameter) and 8", type "A" Mount with maximum recommended speed of 1500 rpm.

