

803 Series Self-Centering Automatic Index Chucks

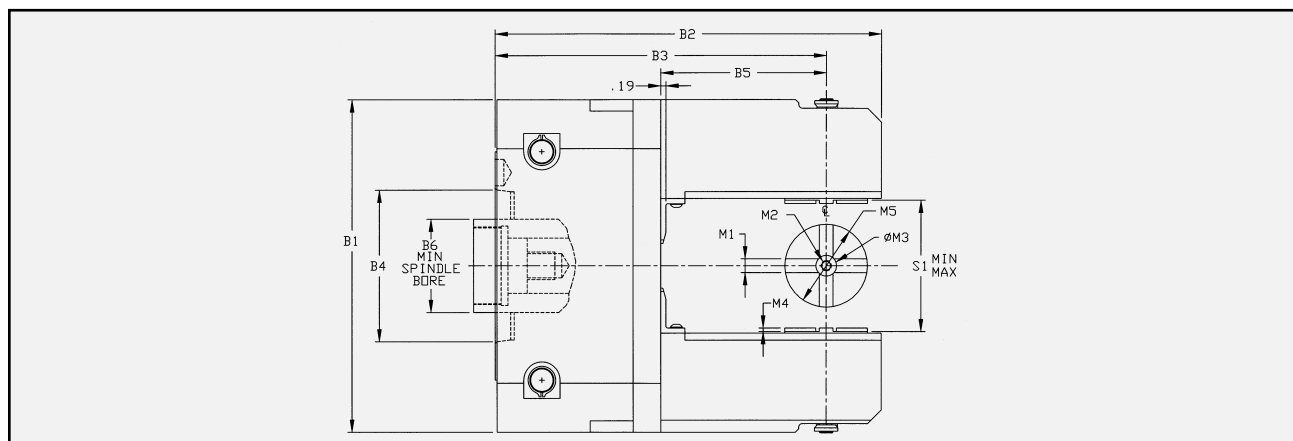

Size	8"	10"	12"	13.5"	15"	18"	21"	24"	28"
Model	803-08	803-10	803-12	803-13	803-15	803-18	803-21	803-24	803-28
Mounting	A5/A6	A6/A8	A6/A8	A8	A8/A11	A11	A11/A15	A15/A20	A15/A20
B1	8.00	10.00	12.00	13.50	15.00	18.00	21.00	24.00	28.00
B2	10.50	11.50	14.00	13.00	14.75	22.75	24.25	27.50	29.50
B3	9.13	10.13	12.00	11.00	12.75	19.50	21.00	22.50	24.50
B4	A5/A6	A6/A8	A6/A8	A8	A8/A11	A11	A11/A15	A15/A20	A15/A20
B5	4.00	5.00	6.00	5.00	5.00	8.62	10.12	11.62	14.50
B6	2.40	2.56	3.38	3.38	3.00	5.13	5.13	5.13	5.00
S1 MAX	3.00	4.00	4.63	6.13	7.75	8.75	11.75	12.75	16.75
S1 MIN	2.00	3.00	3.50	5.00	6.50	6.75	9.75	10.75	14.75
M1	0.500	0.500	0.500	0.500	0.500	0.750	0.750	1.000	1.000
M2	3/8-16	3/8-16	3/8-16	3/8-16	1/2-13	1/2-13	1/2-13	3/4-10	5/8-11
M3	0.750	0.750	0.750	0.750	0.750	DNA	DNA	DNA	DNA
M4	0.125	0.125	0.125	0.125	0.125	0.250	0.250	0.375	0.375
M5	2.00	2.00	3.00	3.00	3.00	3.63	3.63	7.50	7.50

DP Cylinders

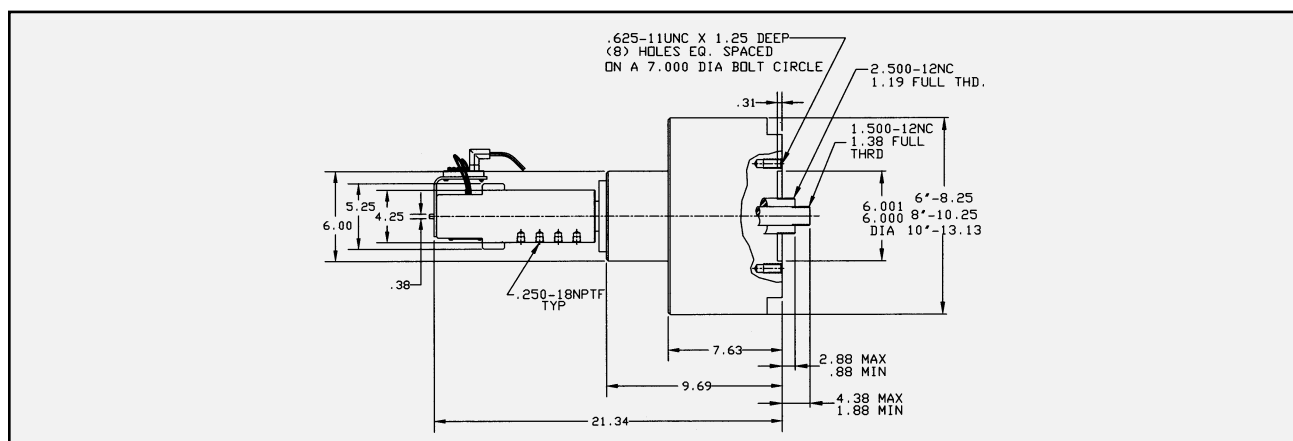

DP cylinders are specifically designed to operate Royal's 803 Series Self-Centering Automatic Index Chucks. These duplex cylinders have independently operated clamping and indexing pistons. The clamp/un-clamp piston as well as the index piston is hydraulically operated assuring maximum clamping force as well as quick indexing and positive index position locking.